

## Low Frequency Transistor (50V,3A)

## STF715A

### FEATURES

- Low saturation voltage:  $V_{CE(sat)}=0.1V$  at  $I_C/I_B=1A/50mA$ .
- Excellent DC current gain characteristics.

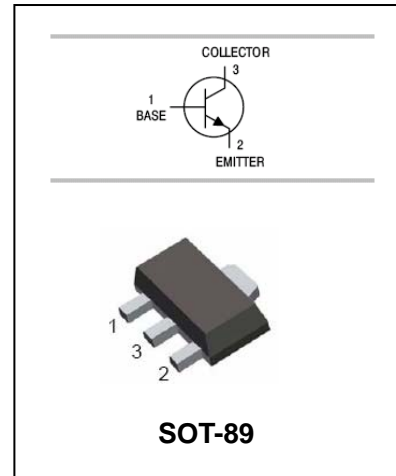

### APPLICATIONS

- Power amplifier application.

### ORDERING INFORMATION

Type No.	Marking	Package Code
STF715A	DKP/DKQ	SOT-89

### MAXIMUM RATING @ $T_a=25^\circ C$ unless otherwise specified

Symbol	Parameter	Value	Units
$V_{CBO}$	Collector-Base Voltage	60	V
$V_{CEO}$	Collector-Emitter Voltage	50	V
$V_{EBO}$	Emitter-Base Voltage	6	V
$I_C$	Collector Current (DC) Collector Current (Pulse)	2 5	A
$P_C$	Collector Dissipation	1500	mW
$T_j, T_{stg}$	Junction and Storage Temperature	-55 to +150	$^\circ C$



**Low Frequency Transistor (50V,3A)**

**STF715A**

**ELECTRICAL CHARACTERISTICS @ Ta=25°C unless otherwise specified**

Parameter	Symbol	Test conditions	MIN	TYP	MAX	UNIT
Collector-base breakdown voltage	$V_{(BR)CBO}$	$I_C=50\mu A, I_E=0$	60			V
Collector-emitter breakdown voltage	$V_{(BR)CEO}$	$I_C=1mA, I_B=0$	50			V
Emitter-base breakdown voltage	$V_{(BR)EBO}$	$I_E=50\mu A, I_C=0$	6			V
Collector cut-off current	$I_{CBO}$	$V_{CB}=60V, I_E=0$			0.1	$\mu A$
Emitter cut-off current	$I_{EBO}$	$V_{EB}=5V, I_C=0$			0.1	$\mu A$
DC current gain	$h_{FE}$	$V_{CE}=2V, I_C=0.5A$	82		270	
		$V_{CE}=2V, I_C=1.5A$	45			
Collector-emitter saturation voltage	$V_{CE(sat)}$	$I_C=1A, I_B=50mA$		0.1	0.35	V
Transition frequency	$f_T$	$V_{CE}=2V, I_E=0.5A, f=100MHz$		210		MHz
Collector output capacitance	$C_{ob}$	$V_{CB}=10V, I_E=0, f=1MHz$		25		pF

**CLASSIFICATION OF  $h_{FE}$**

Rank	P	Q
Range	82-180	150-270
MARKING	DKP	DKQ

**TYPICAL CHARACTERISTICS @ Ta=25°C unless otherwise specified**

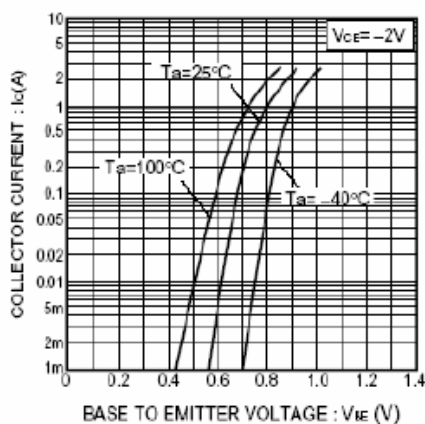

Fig.1 Grounded emitter propagation characteristics

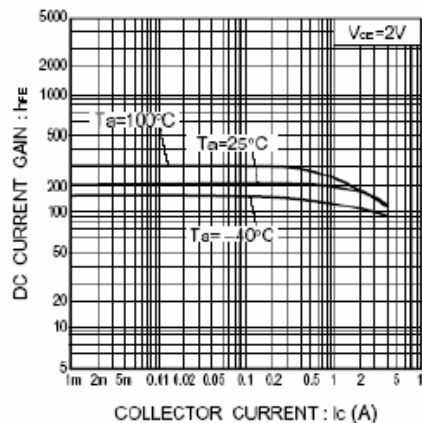

Fig.2 DC current gain vs. collector current

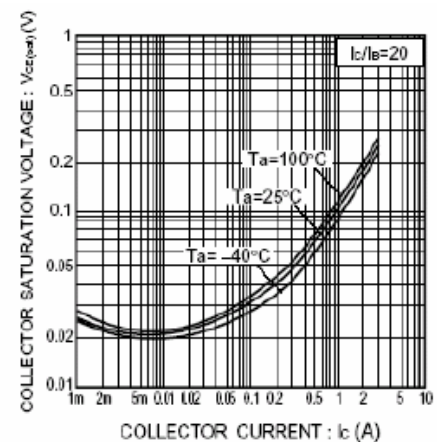

Fig.3 Collector-emitter saturation voltage vs. collector current



**Low Frequency Transistor (50V,3A)**

**STF715A**

**PACKAGE OUTLINE**

Plastic surface mounted package

SOT-89

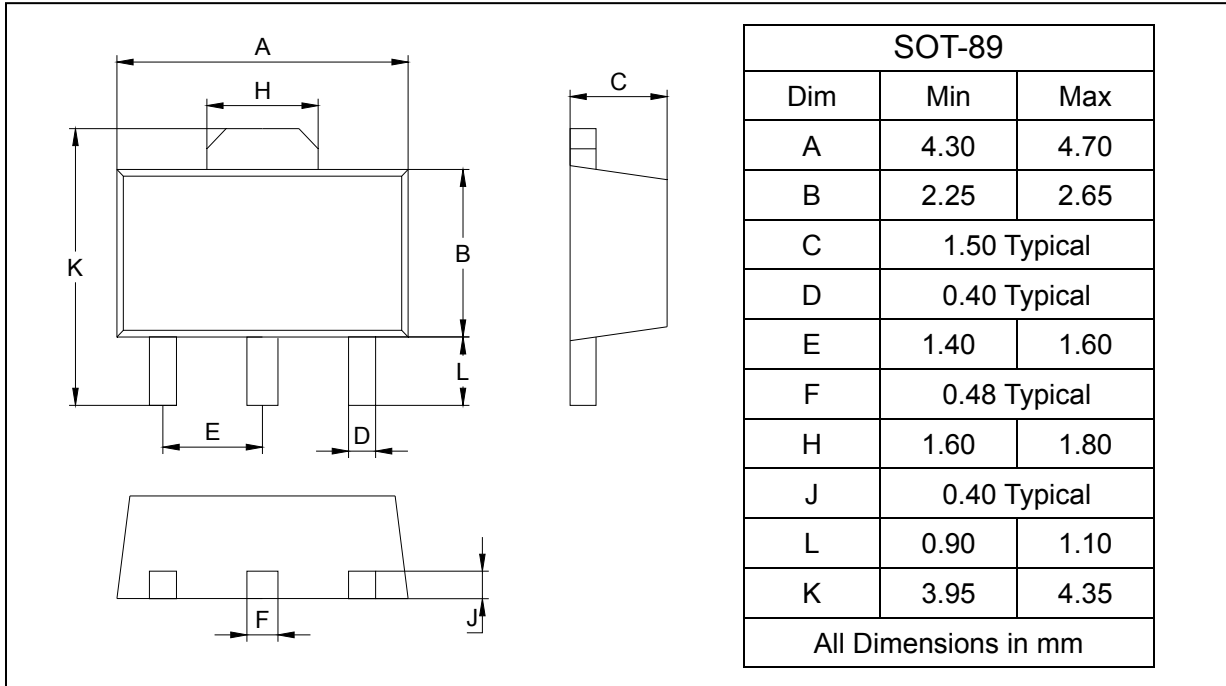

**SOLDERING FOOTPRINT**

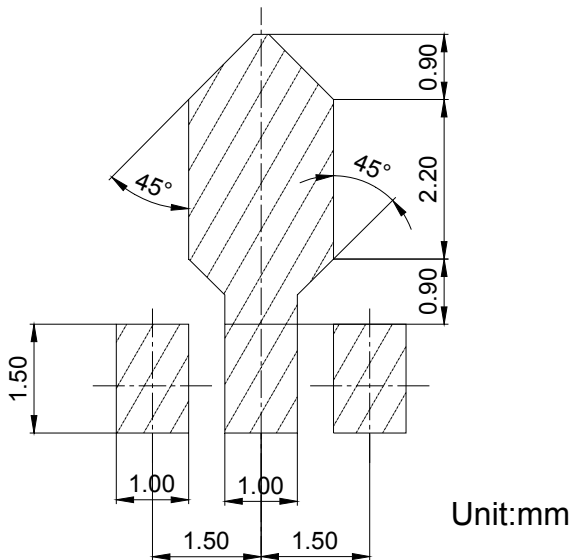

**PACKAGE INFORMATION**

Device	Package	Shipping
STF715A	SOT-89	1000/Tape&Reel